

FLS HF6 LEVEL AND PRESSURE TRANSMITTER



FLS HF6 is a new family of transmitters suitable for hydrostatic level/depth measurement and for pressure monitoring.

PVDF body and ceramic diaphragm with FPM sealing system offer a smart combination of valuable wetted materials.

The semi-flush diaphragm can work properly and for long time in pasty media and with liquids tending to crystallize.

HF6 family can be also the finest choice for clean water applications in case customer would maximize operating time.

The compact design can fit all main applications related to aggressive and corrosive liquids granting different solutions of installation: screw-in (combined with a FIP valve or fitting), submersed with PUR cable running into pipe and submersed with PUR/FEP cable in contact with liquid. Other operating ranges and selectable length of cable in addition to sealing material options offer a customized solution to match the customer needs in the best possible way.

APPLICATIONS

- Storage Tank management
- Liquid inventory control
- Over flow detection
- Water/Wastewater monitoring
- Chemicals processing
- Tank farm management
- Water recycling

MAIN FEATURES

- Level/Pressure/Depth measurement provided by the same transmitter
- Level measurement not affected by foam or vapour
- Premium combination of wetted materials
- Semi flush ceramic diaphragm for a long-lasting operating time
- Options for gauge pressure and for absolute pressure
- Flexible submersible installation (with or without conduit)
- Other operating ranges available on request: full scale @ 600mbar, 1600mbar, 2500mbar, 4000mbar, 6000mbar, 25bar, 40bar (gauge or absolute mode).



TECHNICAL DATA

General

- Operating range: see the table "Specific for HF6"
- Accuracy*: $\leq \pm 0.5$ % FSO *Accuracy according to IEC 60770 – limit point adjustment (non-linearity, hysteresis, repeatability)
- Wetted Materials:
 - Pressure port / housing: PVDF
 - Cable: 8 m PUR (FEP option)
 - Max cable length: 700 m
 - Seals: FPM (EPDM option)
 - Diaphragm ceramics: Al₂O₃ 96%
 - Electromagnetic compatibility emission and immunity according to EN 61326
- Thermal effects (Offset and Span) / Permissible Temperatures:
 - Thermal error: $\leq \pm 0.2$ % FSO / 10 K
 - Compensated range: -25 °C to 85 °C
 - Permissible temperatures:
 - * Medium: -30 to 125 °C
 - * Electronics / environment: -30 to 85 °C
 - * Storage: -30 to 100 °C
- Mechanical stability:
 - Vibration (25 to 2000 Hz) according to DIN EN 60068-2-6
 - Shock 500 g / 1 msec according to DIN EN 60068-2-27
- Enclosure: IP68

- 1*Current output: 4-20mA
- Max loop impedance: $R_{max} = [(V_s - V_s \text{ min}) / 0.02 \text{ A}] \Omega$
- Influence effects:
 - supply: 0.05 % FSO / 10 V
 - load: 0.05 % FSO / k Ω
- Response time: ≤ 10 msec
- Long term stability: $\leq \pm 0,3$ % FSO / year at reference conditions
- Thermal error (Offset and Span): $\leq \pm 0.2$ % FSO/10 K
- Permissible Temperature Range: -25 °C to 85 °C
- Vibration: 10 g RMS (25 ... 2000 Hz) according to DIN EN 60068-2-6
- Shock 500 g / 1 msec according to DIN EN 60068-2-27

Environmental

- Operating temperature:
 - medium: -30 to 125 °C (-22 to +257 °F) - referred to in line installation
 - electronics / environment: -30 to +85 °C (-22 to +185 °F)
- Storage temperature: -30 to +100 °C (-22 to +212 °F)

Standard & Approvals

- Manufactured under ISO9001
- CE

Electrical

- Supply voltage (VS): 8 to 32 VDC
- Current consumption: max. 25 mA

Specific for HF6					
Model	Nominal pressure gauge [bar]	Level [mH ₂ O]	Overpressure [bar]	Burst pressure [bar]	Vacuum resistance [bar]
HF6.004	0.4	4	1	2	PN \geq 1 bar: unlimited vacuum resistance PN < 1 bar: on request
HF6.010	1	10	2	4	
HF6.100	10	100	20	30	
HF6.160	16	160	40	50	

Maximum Operating Pressure/Temperature (using thread for coupling)

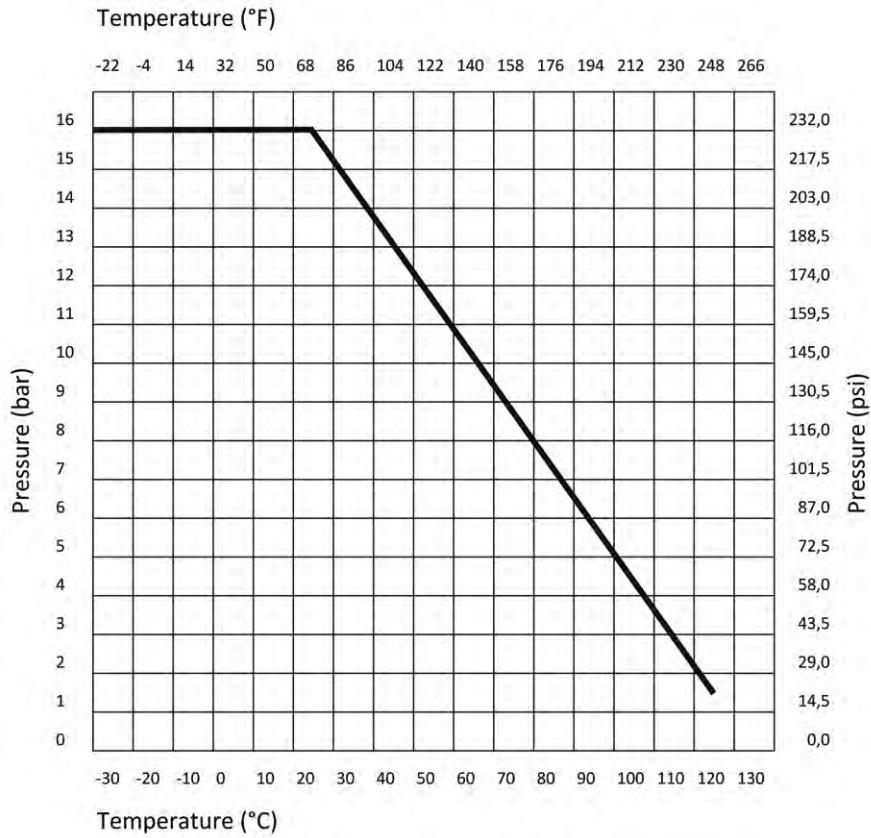

Data refers to water and non-hazardous fluids for which the material is classified as chemically resistant (25 years lifetime).

DIMENSIONS

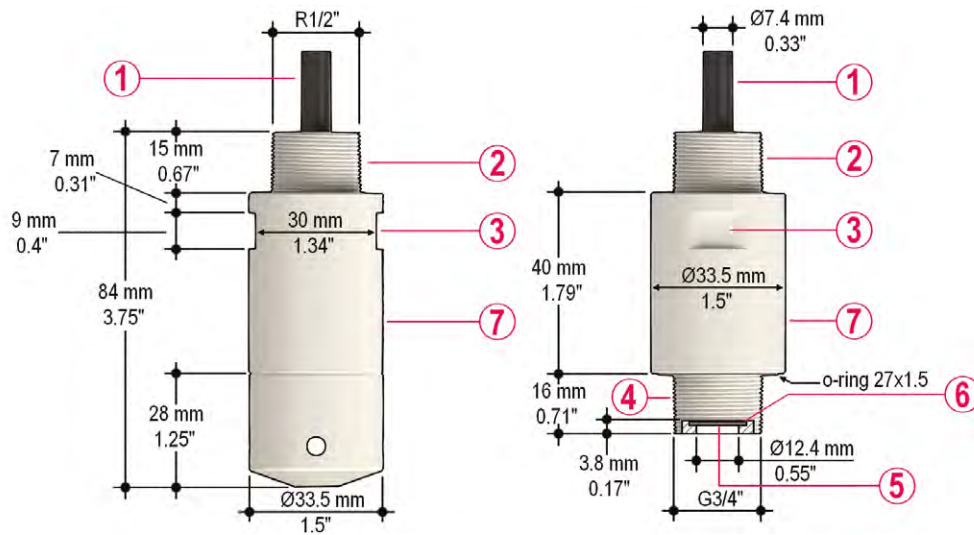

- 1 Cable PUR 8m
- 2 Thread (R 1/2")
- 3 Wrench flat
- 4 Thread (G 3/4")
- 5 FPM O-ring
- 6 Ceramic diaphragm
- 7 Body: PVDF

ORDERING DATA

HF6.XXX Level and Pressure Transmitter								
Part No.	Description/ Name	Applications/ Operative Range	Process connection	Main Wetted Materials	Measuring Mode	Diaphragm	Cable	Weight (g)
HF6.004	Level/Pressure Hydrostatic Transmitter	0-400mbarg	STD: ¼" G (class A) SUBMERSED: ½" R (class A)	PVDF, PUR, FPM, ceramic	Relative Pressure	Ceramic/ Semi flush	PUR 8m	550
HF6.010	Level/Pressure Hydrostatic Transmitter	0-1000mbarg	STD: ¼" G (class A) SUBMERSED: ½" R (class A)	PVDF, PUR, FPM, ceramic	Relative Pressure	Ceramic/ Semi flush	PUR 8m	550
HF6.100	Level/Pressure Hydrostatic Transmitter	0-10barg	STD: ¼" G (class A) SUBMERSED: ½" R (class A)	PVDF, PUR, FPM, ceramic	Relative Pressure	Ceramic/ Semi flush	PUR 8m	550
HF6.160	Level/Pressure Hydrostatic Transmitter	0-16barg	STD: ¼" G (class A) SUBMERSED: ½" R (class A)	PVDF, PUR, FPM, ceramic	Relative Pressure	Ceramic/ Semi flush	PUR 8m	550

Other versions available:

- SS AISI630 body equipped with SS AISI630 flush diaphragm and ranges from 0-1bar up to 0-100bar (gauge mode).
- SS AISI316L body equipped with ceramic diaphragm and ranges from 0-0.1bar up to 0-25bar (gauge or absolute mode).