

REAL CONTROLLER PRO

WATER QUALITY
MONITORING
SOLUTIONS



FEATURES & BENEFITS

- 10" colour LCD, touch screen graphic interface
- Easy to navigate Smart Sense software
- Multiple sensor and accessory integration
- Quick analysis of historic trends in seconds
- Modbus TCP, Modbus (RS485) standard
- Optional WiFi, 4-20 mA, cellular modem

OVERVIEW

Full control and monitoring of multiple sensors can be achieved with the plug and play Real Controller Pro. Featuring a 10" colour LCD touch screen graphic interface, the controller offers superior functionality and configurability while maintaining ease of use and navigation. The controller provides proprietary inputs for multiple Real Tech sensors and accessories bringing all water quality data to a single location - making analysis quick and simple. Modbus RS485 and Modbus TCP/IP are standard with optional 4-20 mA input, 4-20 mA output, dry contacts, WiFi module and cellular modem.

CONTROLLER UPGRADES

PRODUCT #	NAME	DESCRIPTION
S-164111	WiFi for Real Controller Pro	WiFi module for remote connectivity
S-168111	4-20 mA input (4)	4-20 mA input module, four channel
S-178113	4-20 mA output (1)	4-20 mA output module, one channel
S-178114	4-20 mA output (2)	4-20 mA output module, two channel
S-178115	4-20 mA output (4)	4-20 mA output module, four channel
S-168120	Digital I/O dry contact module	4 input and 4 output dry contacts
S-184101	Cellular Modem - Ethernet	Cell based monitoring system for Real Controller Pro



REALTECH
INC.

SPECIFICATIONS

CHARACTERISTIC	TECHNICAL DATA
Product #	S-11TPC (Interface inside cabinet) or S-11TPCD (interface external on cabinet door)
Compatibility	All sensors
Display/ Operator Interface	10" colour LCD 1024 x 768, Touch screen graphical interface
Operating System	Windows Embedded
Memory	32 GB
Inputs	Proprietary inputs for Real Tech sensors and accessories. Optional 4-20 mA inputs for plug and play sensors, dry contact inputs.
Alarms	Display of sensor specific alarms. Aggregate alarms.
Communication	Modbus TCP, Modbus (RS485) standard. Optional 4-20 mA, WiFi, cellular modem
Data Logging	Onboard (18 months nominal configuration dependent). Optional remote data logging. Export data via USB
Electrical	24VDC 13.4A power adapter (accepts 90-250VAC 50/60Hz)
Enclosure	NEMA 4, wall mountable
Dimensions	19.0"H x 20.5"W x 9.0"D
Operating Temp	0 to 45°C (32 to 113°F)
Storage Temp	-20 to 60°C (-4 to 140°F)
Weight	35 lb
Warranty	2-year limited warranty

* Technical Specifications are subject to change without notice.

DIMENSIONS

The Real Controller Pro is installed directly on a wall, railing or system backboard.

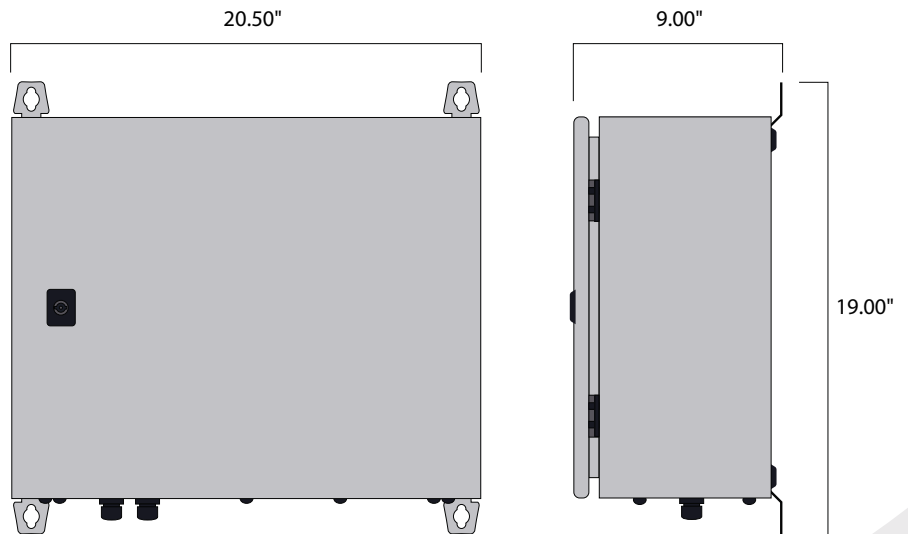

Real Tech Inc.

1150 Champlain Court,
Whitby, Ontario L1N 6K9 Canada
TF: 1.877.779.2888 T: 1.905.665.6888
info@realtechwater.com



(주)엠씨마스터스

MC Masters
Measurement & Control

REALTECH
INC.